



# APsystems Microinverter User Manual

## APsystems EZ1-LV Microinverters

(For North America)



ALTENERGY POWER SYSTEM Inc.  
Usa.APsystems.com

APsystems USA  
8627 N. Mopac Expy, Suite 150, Austin, TX 78759  
EMAIL: info.usa@APsystems.com



Please scan this QR code to have access to our APPs and Products Information.

# Table of Contents

|   |           |
|---|-----------|
| <b>1. Important Safety Instructions</b> .....               | <b>2</b>  |
| 1.1 Safety Instructions .....                               | 2         |
| 1.2 Radio Interference Statement .....                      | 3         |
| 1.3 Symbols in Lieu of Words .....                          | 4         |
| <b>2. APsystems Microinverter System Introduction</b> ..... | <b>5</b>  |
| <b>3. APsystems Microinverter EZ1-LV Introduction</b> ..... | <b>7</b>  |
| <b>4. APsystems Microinverter System Installation</b> ..... | <b>8</b>  |
| 4.1 Additional Accessories Supplied by APsystems .....      | 8         |
| 4.2 Installation Procedures .....                           | 8         |
| <b>5. Install and Use AP EasyPower</b> .....                | <b>11</b> |
| 5.1 Install APP .....                                       | 11        |
| 5.2 Connect the APsystems Microinverters .....              | 11        |
| 5.3 Monitor & Control .....                                 | 12        |
| <b>6. Troubleshooting</b> .....                             | <b>13</b> |
| 6.1 Status Indications and Error Reporting .....            | 13        |
| 6.2 Trouble Shooting Guide .....                            | 13        |
| 6.3 APsystems Technical Support .....                       | 13        |
| 6.4 Maintenance .....                                       | 13        |
| <b>7. Replace a Microinverter</b> .....                     | <b>14</b> |
| <b>8. Technical Data</b> .....                              | <b>15</b> |
| 8.1 EZ1-LV Microinverter Datasheet .....                    | 16        |
| <b>9. EZ1-LV Accessory</b> .....                            | <b>17</b> |

# 1. Important Safety Instructions

This manual contains important instructions to follow during installation and maintenance of the APsystems Photovoltaic Grid-connected Microinverter. To reduce the risk of electrical shock and ensure a safe installation and operation of the APsystems Microinverter, the following symbols appear throughout this document to indicate dangerous conditions and important safety instructions.

Specifications are subject to change without notice. Please ensure you are using the most recent update found at <https://usa.apsystems.com/resources/library/> or <https://canada.apsystems.com/resources/library/>

## **WARNING:**

This indicates a situation where failure to follow instructions may cause a serious hardware failure or personnel danger if not applied appropriately. Use extreme caution when performing this task.

## **NOTICE:**

This indicates information that is important for optimized microinverter operation. Follow these instructions closely.

## 1.1 Safety Instructions

- ✓ **Do NOT** disconnect the PV module from the APsystems Microinverter without first disconnecting the AC power.
- ✓ Only qualified professionals should install and/or replace APsystems Microinverters.
- ✓ Perform all electrical installations in accordance with local electrical codes.
- ✓ Before installing or using the APsystems Microinverter, please read all instructions and cautionary markings in the technical documents and on the APsystems Microinverter system and the solar-array.
- ✓ Be aware that the body of the APsystems Microinverter is the heat sink and can reach a temperature of 80° C. To reduce risk of burns, do not touch the body of the Microinverter.
- ✓ **Do NOT** attempt to repair the APsystems Microinverter. If it fails, contact APsystems Customer Support to obtain an RMA number and start the replacement process. Damaging or opening the APsystems Microinverter will void the warranty.
- ✓ **Caution!**  
The external protective earthing conductor is connected to the inverter protective earthing terminal through AC connector. When connecting, connect the AC connector first to ensure the inverter earthing then do the DC connections. When disconnecting, disconnect the AC by opening the branch circuit breaker first but maintain the protective earthing conductor in the branch circuit breaker connect to the inverter ,then disconnect the DC inputs.
- ✓ Please install AC breakers on the AC side of the inverter.
- ✓ **CAUTION** – Hot surfaces - To reduce the risk of burns - Do not touch. Risk of electric shock-(a) both ac and dc voltage source are terminated inside this equipment. Each circuit must be individually disconnected before servicing, and (b) When the photovoltaic array is exposed to light, it supplies a dc voltage to this equipment. Warranty void if cover removed. No user serviceable parts inside.Refer servicing to qualified service personnel. This inverter has an integral ground-fault detector / interrupter (GFDI).This Utility-InteractiveInverter contains active anti-islanding protection(IEEE1547) and is tested per FCC/IC.

# 1. Important Safety Instructions

## 1.2 Radio Interference Statement

This equipment has been tested and found to comply with the limits for a Class B digital device, pursuant to part 15 of the FCC Rules. These limits are designed to provide reasonable protection against harmful interference in a residential installation. This equipment generates, uses and can radiate radio frequency energy and, if not installed and used in accordance with the instructions, may cause harmful interference to radio communications. However, there is no guarantee that interference will not occur in a particular installation. If this equipment does cause harmful interference to radio or television reception, which can be determined by turning the equipment off and on, the user is encouraged to try to correct the interference by one or more of the following measures:

- Reorient or relocate the receiving antenna.
- Increase the separation between the equipment and receiver.
- Connect the equipment into an outlet on a circuit different from that to which the receiver is connected.

Consult the dealer or an experienced radio/TV technician for help.

FCC Caution: FCC STATEMENT

1. This device complies with Part 15 of the FCC Rules. Operation is subject to the following two conditions:

(1) This device may not cause harmful interference, and

(2) This device must accept any interference received, including interference that may cause undesired operation.

2. any Changes or modifications not expressly approved by the party responsible for compliance could void the user's authority to operate the equipment.

FCC Radiation Exposure Statement

This equipment complies with FCC radiation exposure limits set forth for an uncontrolled environment. This equipment should be installed and operated with minimum distance 20cm between the radiator & your body.

# 1. Important Safety Instructions

## 1.3 Symbols in Lieu of Words

 **APsystems** Trademark.



Caution, risk of electric shock.



Caution, hot surface.



NOTICE, danger! This device directly connected with electricity generators and public grid.

Qualified personnel

Person adequately advised or supervised by an electrically skilled person to enable him or her to perceive risks and to avoid hazards which electricity can create. For the purpose of the safety information of this manual, a "qualified person" is someone who is familiar with requirements for safety, electrical system and EMC and is authorized to energize, ground, and tag equipment, systems, and circuits in accordance with established safety procedures. The inverter and photovoltaic system may only be commissioned and operated by qualified personnel.

## 2. APsystems Microinverter System Introduction

The EZ1-LV APsystems Microinverter is used in balcony and DIY systems which comprised of the below key elements:

- PV modules
- US Power Cord
- EZ1-LV microinverter
- Router
- Cell phone

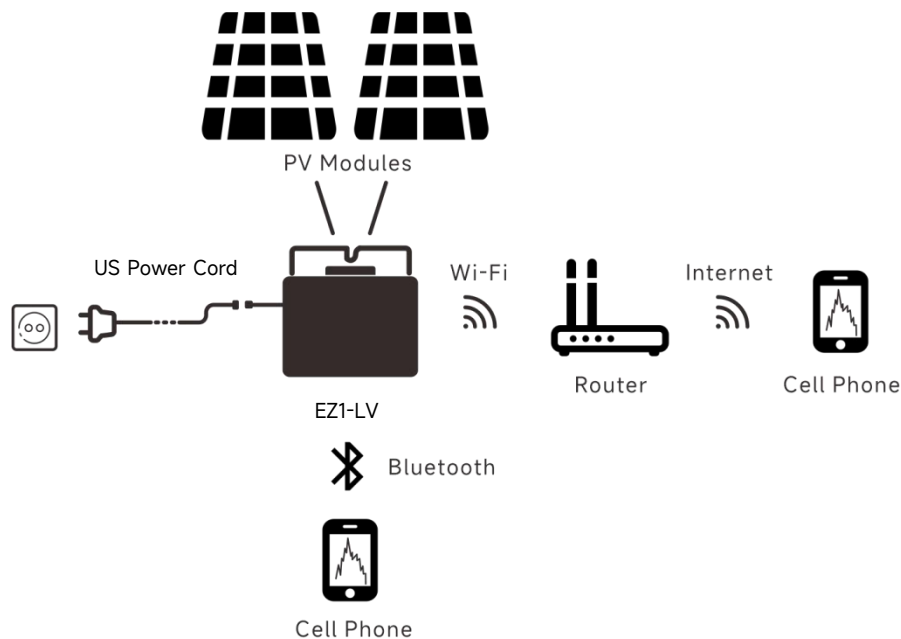

EZ1-LV microinverters have 2 input channels with independent MPPT and high input current and output power to adapt to today's larger power module. Users could directly connect to the EZ1-LV with their cell phones through Bluetooth and get the real-time data of the solar systems. Besides direct connection, EZ1-LV could also connect to a router through Wi-Fi and send data to cloud servers for remote monitoring.

Through a power cord provided by APsystems, EZ1-LV could be plugged into a socket and start output energy, truly easy and convenient grid connection.

1. If the wireless signal in the area where the microinverter is weak, it is necessary to add a Wi-Fi signal booster at a suitable place between the router and the microinverter.
2. The EZ1-LV product is only suitable for the following DIY application scenarios, such as balcony, garden, garage, and carport. The EZ1-LV is not suitable for the rooftop system application scenario.
3. The EasyPower App supports monitoring up to 4 products from the EZ1-LV.

## 2. APsystems Microinverter System Introduction

This integrated system improves safety; maximizes solar energy harvest; increases system reliability, and simplifies solar system design, installation, maintenance, and management.

### **Safety with APsystems Microinverters**

In a typical string inverter installation, PV modules are connected in series. The voltage adds-up to reach high voltage value (from 600Vdc up to 1000Vdc) at the end of the PV string. This extreme high DC voltage brings a risk of electrical shocks or electrical arcs which could cause fire.

When using an APsystems microinverter, PV modules are connected in parallel. Voltage at the back of each PV module never exceeds PV modules Voc, which is lower than 60Vdc for most of PV modules used with APsystems microinverters. This low voltage negates the risk of electrical shock, electrical arcs and fire hazards.

### **APsystems Microinverters maximize PV energy production**

Each PV module has individual Maximum Peak Power Tracking (MPPT) control, which ensures that the maximum power is produced to the utility grid regardless of the performance of the other PV modules in the array. When PV modules in the array are affected by shade, dust, different orientation, or any situation in which one module underperforms compared with the other units, the APsystems Microinverter ensures top performance from the array by maximizing the performance of each module individually within the array.

### **More reliable than centralized or string inverters**

APsystems Microinverters are designed to operate at full power at ambient outdoor temperatures of up to 65 deg C (or 149 F). The inverter case is designed for outdoor installation and complies with the Type 6 environmental enclosure rating.

### **Simple to install**

EZ1-LV micorinverters have 2 input channels with independent MPPT and high input current and output power to adapt to today's larger power module. Users could directly connect to the EZ1-LV with their cell phones through Bluetooth and get the real-time data of the solar systems. Besides direct connection, EZ1-LV could also connect to a router through Wi-Fi and send data to cloud servers for remote monitoring.

Through an AC extension cable provided by APsystems, EZ1-LV could be plugged into a socket and start output energy, truly easy and convenient grid connection.

## 3. APsystems Microinverter EZ1-LV Introduction

### Key Product Feature:

- One microinverter connects to two modules with independent MPPT
- Max output power reaching 900VA for different models
- High Input current to adapter to large modules
- Built in Wi-Fi and Bluetooth
- Safety protection relay integrated
- Dedicated for balcony and DIY systems
- Directly plug into wall socket

## 4. APsystems Microinverter System Installation

### 4.1 Additional Accessories Supplied by APsystems

- US Power Cord

### 4.2 Installation Procedures

#### 4.2.1 Step 1 - Verify that Grid Voltage Matches Microinverter Rating

Do NOT carry the microinverter by the AC cable. This may cause the AC cable to partially or fully disconnect from the unit, resulting in no or poor operation.

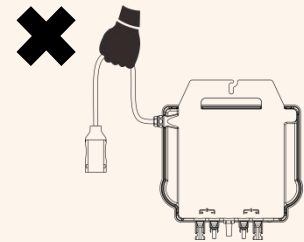

#### 4.2.2 Step 2 - Install the Microinverters In Proper Position

The Microinverter EZ1-LV can be installed on the balcony wall or fixed to the railing using cable ties. Select an appropriate installation method based on your actual scenario to ensure that the EZ1-LV is securely installed.

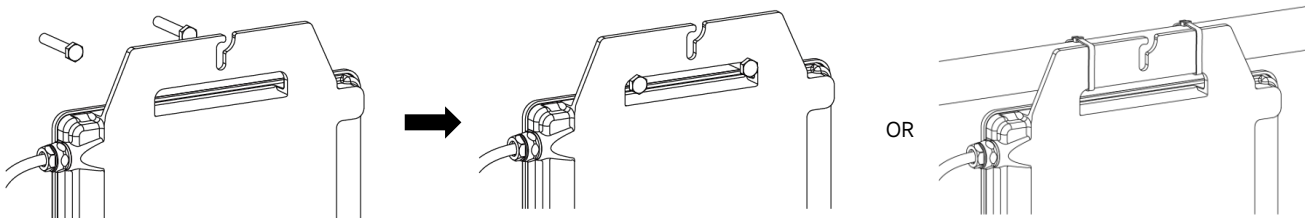

Install the microinverters in proper position to avoid direct exposure to rain, UV or other harmful weather events.

#### 4.2.3 Step 3 - Connect APsystems Microinverters to the PV Modules

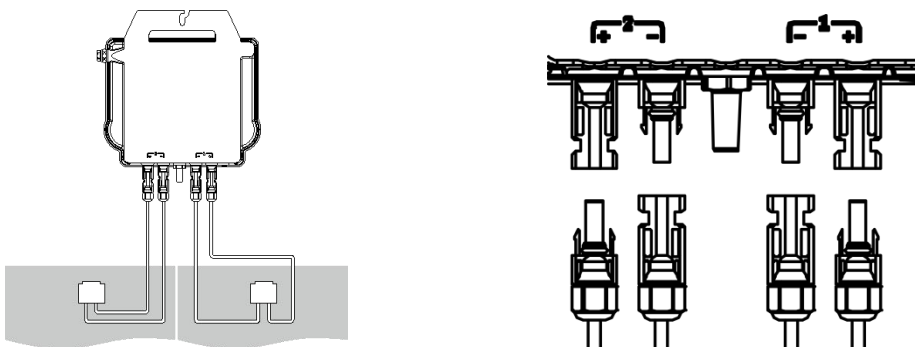

When plugging in the DC cables, the microinverter should immediately blink green ten times. This will happen as soon as the DC cables are plugged in and will show that the microinverter is functioning correctly. This entire check function will start and end within 10 seconds of plugging in the unit, so pay careful attention to these lights when connecting the DC cables.

## 4. APsystems Microinverter System Installation

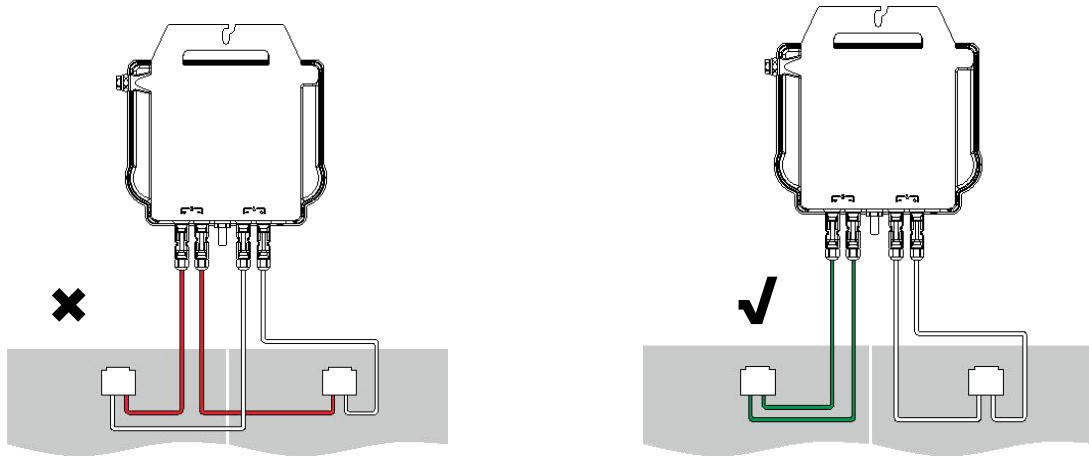

Each PV panel must be carefully connected to the same channel.

Make sure to not split positive and negative DC cables into two different input channels: microinverter will become damaged and warranty will not apply.

### 4.2.4 Step 4 - Connect the APsystems Microinverter to US Power Cord

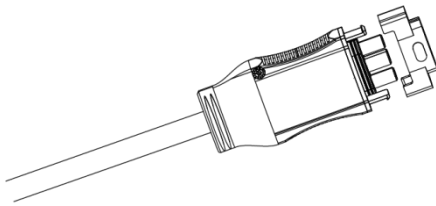

Remove the bus cable Y-CONN protective sleeve before power cord connection.

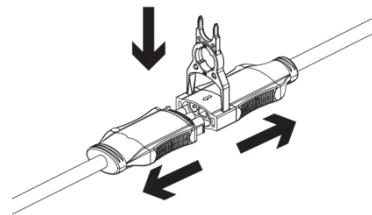

**Best Practice:** Use the Unlock Tool to disconnect the connectors. (The Unlock Tool is included in the package, please safekeeping.)

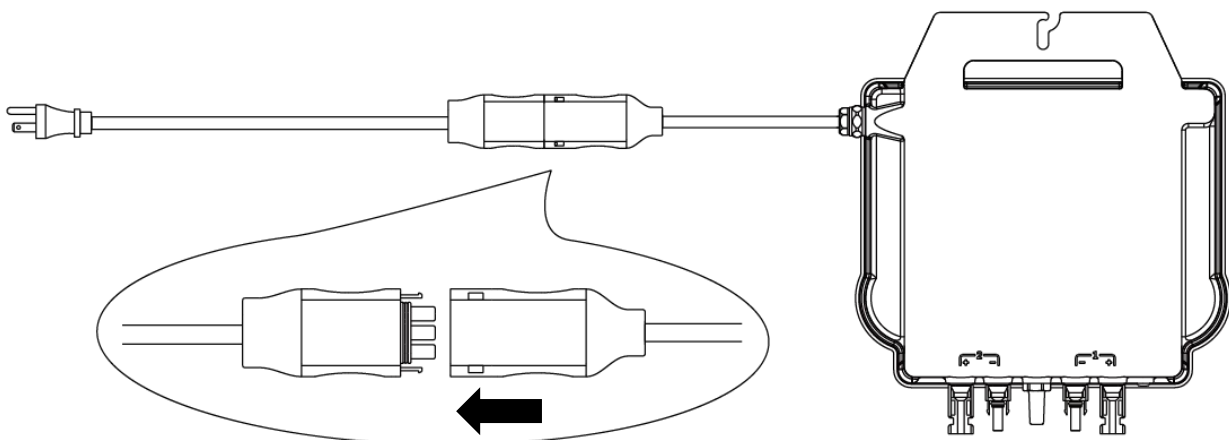

**Single device:** Insert the microinverter AC connector into the power cord connector. Make sure to hear the “click” as a proof of robust connection.

## 5. Install and Use AP EasyPower

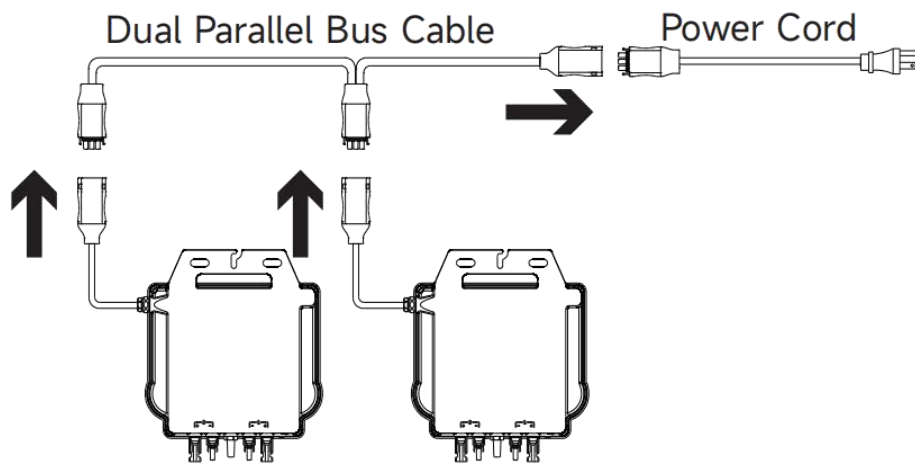

**Two device:** The microinverter can also have two units connected in parallel to the power line.

If the dual parallel bus cable and power cord are not included in the package and should be purchased separately. Please contact the salesperson or your dealer for details.

### 4.2.5 Step 5 - Insert the US Power Cord Into the Socket

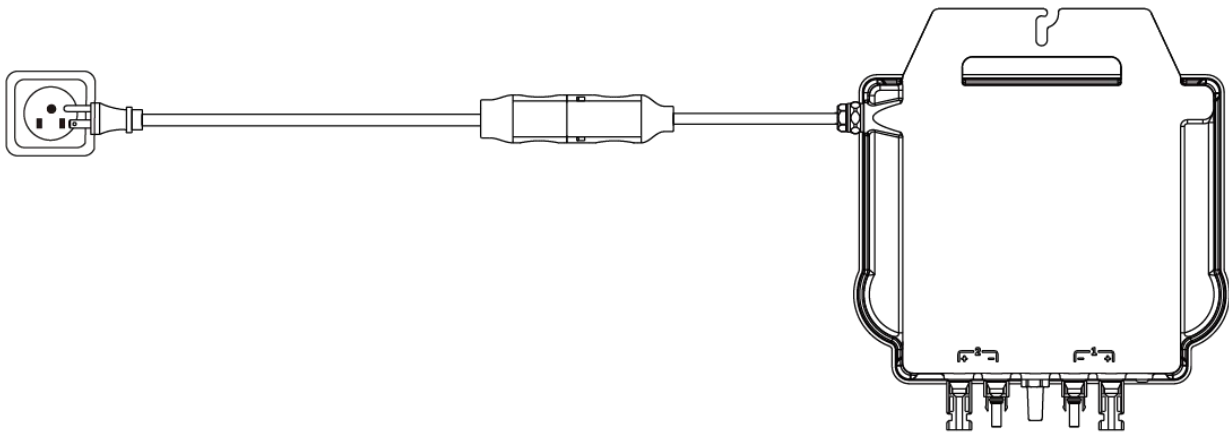

**\*Note:** If there are discrepancies between the diagrams in the user manual and the actual product, please refer to the actual product.

# 5. Install and Use AP EasyPower

## 5.1 Install APP

Please scan QR code below to have access to our products and APP catalogue, or click this link to download our APPs: <https://file.apsystemsema.com:8083/apsystems/apeasypower/download.html> .



### iOS:

- Go to App Store
- Search “AP EasyPower”
- Download and install

iOS: 10.0 and up.

### Android:

#### Method 1

- Go to Google Play Store
- Search “AP EasyPower”
- Download and install

#### Method 2

- Open <https://apsystems.com>
- Select your region
- Click the tab menu “Apps” below “Products”
- Download and install

Android: 7.0 and up.

## 5.2 Connect the APsystems Microinverters

AP EasyPower offers two modes “Direct Connect Mode” and “Remote Mode” to monitor the device.

**Direct Connect Mode:** APP connects to Bluetooth of the device, so that users can realize local monitoring and control of the device.

**Remote Mode:** Login account, users can realize remote monitoring and control of the device.

1. In the absence of Wi-Fi, users can monitor and control the device in direct connection mode.

2. You are able to link up to 4 devices to your account, just repeat the linking device operations until linking all your devices.

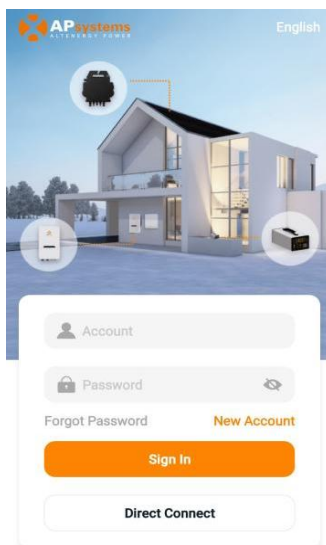

Copyright 2023 © Altenergy Power System Inc.



# 5. Install and Use AP EasyPower

## 5.3 Monitor & Control

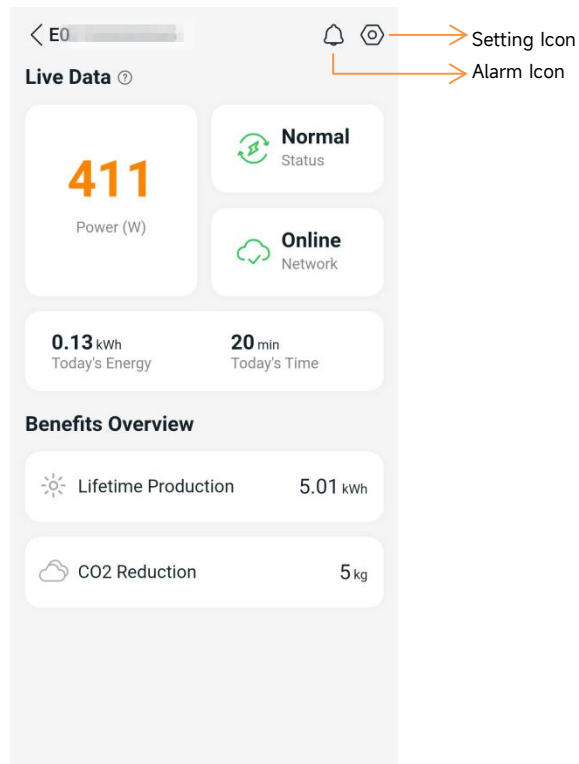

On this page, user can visualize

- **Live Data:** The real-time data of the device in current round, including the power, energy, running time, working status and the cloud status.
  - Working status
    - Normal:** The device is working normally.
    - Alarm:** The device has alarms and you need to check it.
  - Cloud status
    - Online:** The device is connecting the cloud service through the internet.
    - Offline:** The device is not connecting the cloud service through the internet, maybe the device is not connected the Wi-Fi or the router is down.
  - **Benefits Overview:** The lifetime energy produced by the device and the equivalent CO2 reduction.
- By pressing “**alarm icon**” to check the alarm information if the device status is alarm.
- By pressing “**setting icon**” to set the device. The setting page is shown below.

For Connection and monitoring operation mode, please refer to the AP EasyPower User Manual.

## 6. Troubleshooting

Users can use the following troubleshooting steps if the PV system does not operate correctly:

### 6.1 Status Indications and Error Reporting

Assuming they are easily accessible and visible, Operation LEDs can give a good indication of the microinverters status

#### 6.1.1 Start up LED

Ten short green blinks when DC power is first applied to the Microinverter indicates a successful Microinverter startup.

#### 6.1.2 Operation LED

Flashing Slow Green (5 sec. gap) - Producing power and the Microinverter is in normal working status.

Flashing Slow Red (5 sec. gap) - The Microinverter is in protection status or disconnected from grid.

#### 6.1.3 GFDI Error

A solid red LED indicates the Microinverter has detected a Ground Fault Detector Interrupter (GFDI) error in the PV system. Please check if the DC inputs of the inverter are mistakenly connected to ground or contact your local APsystems Technical Support.

### 6.2 Trouble Shooting Guide

Professional Users can also refer to our Troubleshooting Guide (<https://usa.apsystems.com/resources/library/> or <https://canada.apsystems.com/resources/library/>, section libraries) for more in depth guidelines on how to troubleshoot and fix PV installations powered by APsystems microinverters.

### 6.3 APsystems Technical Support

The APsystems local Technical Support team is available to support professional installers in becoming familiar with our products and to troubleshoot installations when needed.

Do not attempt to repair APsystems Microinverters. Please contact your local APsystems Technical Support.

- ①. Never disconnect the DC wire connectors under load. Ensure that no current is flowing in the DC wires prior to disconnecting.
- ②. Always disconnect AC power before disconnecting the PV module wires from the APsystems Microinverter.
- ③. The APsystems Microinverter is powered by PV module DC power. AFTER disconnecting the DC power, when reconnecting the PV modules to the Microinverter, be sure to watch for the ten short green LED flashes.

### 6.4 Maintenance

APsystems microinverters do not require any specific regular maintenance.

## 7. Replace a Microinverter

### Follow the procedure to replace a failed APsystems Microinverter

- A. Disconnect the APsystems Microinverter from the PV Module, in the order shown below:
  1. Disconnect the inverter from grid
  2. Disconnect the PV module DC wire connectors from the microinverter.
  3. Remove the Microinverter from the PV array racking.
- B. Install a replacement Microinverter to the rack. Remember to observe the flashing green LED light as soon as the new Microinverter is plugged into the DC cables.
- C. Insert the microinverter AC connector into the power cord connector.
- D. Connect the inverter to grid and verify proper operation of the replacement Microinverter.

## 8. Technical Data

- ①. Be sure to verify that the voltage and current specifications of your PV module are compatible with the range allowed on APsystems Microinverter. Please check the microinverter datasheet.
- ②. DC operating voltage range of the PV module must be within allowable input voltage range of the APsystems Microinverter.
- ③. The maximum open circuit voltage of the PV module must not exceed the specified maximum input voltage of the APsystems.

# 8.1 EZ1-LV Microinverter Datasheet

## Model

**EZ1-LV**

### Input Data (DC)

|   |               |
|---|---------------|
| Recommended PV Module Power (STC) Range | 315Wp-660Wp+  |
| Peak Power Tracking Voltage             | 27V-45V       |
| Operating Voltage Range                 | 26V-60V       |
| Maximum Input Voltage                   | 60V           |
| Maximum Input Current                   | 18A x 2       |
| Maximum input short circuit current     | 25A per input |

### Output Data (AC)

|                                   |                                     |
|-----------------------------------|-------------------------------------|
| Maximum Continuous Output Power   | 900VA                               |
| Nominal Output Voltage/Range      | 120V/105.6-132V                     |
| Nominal Output Current            | 7.5A                                |
| Nominal Output Frequency/ Range   | 60Hz/58.8Hz-61.2Hz (HECO:57Hz-63Hz) |
| Power Factor (Default/Adjustable) | >0.99(-0.9~0.9 adjustable)          |

### Efficiency

|                         |       |
|-------------------------|-------|
| Peak Efficiency         | 96%   |
| Nominal MPPT Efficiency | 99.5% |
| Night Power Consumption | 20mW  |

### Mechanical Data

|                                     |   |
|-------------------------------------|---|
| Operating Ambient Temperature Range | -40°F to +149°F(- 40 °C to + 65 °C)         |
| Storage Temperature Range           | -40°F to +185°F(- 40 °C to + 85 °C)         |
| Dimensions (W x H x D)              | 11.1" × 9.2" × 1.6"(283mm x 233mm x 39.5mm) |
| Weight                              | 9.3lbs(4.2kg)                               |
| DC Connector Type                   | MC4 Compatible                              |
| Cooling                             | Natural Convection - No Fans                |
| Enclosure Environmental Rating      | Type 6                                      |

### US Power Cord

|              |                    |
|--------------|--------------------|
| Wire Size    | 16AWG              |
| Cable Length | 5M as default      |
| Plug Type    | 120V Standard plug |

### Features

|                         |  |
|-------------------------|--|
| Communication           | Built-in Wi-Fi and Bluetooth                       |
| Maximum units connected | 2  |
| Isolation Design        | High Frequency Transformers, Galvanically Isolated |
| Energy Management*      | AP EasyPower APP                                   |
| Warranty                | 12 Years Standard                                  |

### Compliances

|                                |  |
|--------------------------------|--|
| Safety, EMC & Grid Compliances | UL1741; CSA C22.2 No.107.1-16; FCCPart15B; IECs-003; IEEE1547; UL1741SB; SRD-V2.0; NEC2014 & NEC2017 & NEC2020 & NEC2023 Section 690.11 DC Arc-Fault circuit Protection NEC2014 & NEC2017 & NEC2020 & NEC2023 Section 690.12 Rapid Shutdown of PV systems on Buildings |
|--------------------------------|--|

\* The EasyPower App supports monitoring up to 4 products from the EZ1-LV.

\*\*The EZ1-LV product is only suitable for the following DIY application scenarios, such as balcony, garden, garage, and carport. The EZ1-LV is not suitable for the rooftop system application scenario.

© All Rights Reserved

*Specifications subject to change without notice please ensure you are using the most recent update found at web : [usa.APsystems.com](http://usa.APsystems.com)*

## 9. EZ1-LV Accessory

### 9.1 Dimensions

